

İLERİ GERİ ÜNİTELİ PNÖMATİK HASSAS EKİM MAKİNASI (SOĞAN İÇİN)

PNEUMATIC PRECISION PLANTER
(NARROW ROW SPACE FOR ONION)

ŞK-PMB-İG SERİSİ / SERIES



VIDEO KULLANMA
KLAVUZU
VIDEO USE GUIDE





ŞK-PMB-İG
SERİSİ / SERIES



GENEL ÖZELLİKLER



GENERAL SPECIFICATIONS



Özel fan sayesinde her tür tohum ekilebilir. Ekim plakaları, ayarlanabilir basınçlı hava üflemesi ile tohum kalıntılarında temizlenir. Fan üzerinde vakum ve basınç göstergeleri mevcuttur.

Through special fan is possible to sowing every type of seeds. The setup able Sowing plates is cleaning with compressed air blowing system from remnants seeds. On the fan is vacuum and air pressure indicator extant.



Tohum temizleme düzeneği
Seed cleaning device

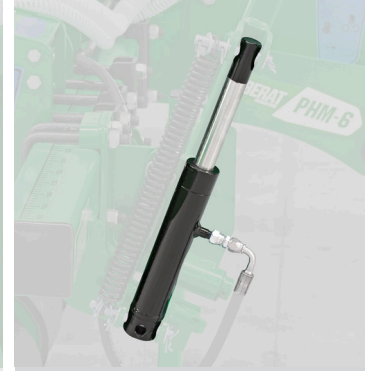

Koldan hidrolik markör sistemi: Her kolun bağımsız hareket etmesini sağlar.
Hydraulic marker system: Provides each marker arm moving independently.

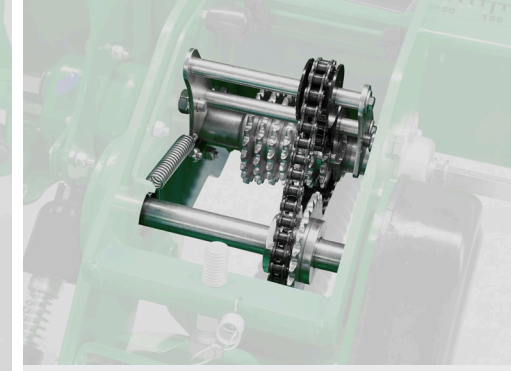

Tohum sıra üstü mesafesi ayar şanzımanı. Tohum ara mesafeleri dişli kutusudaki dişlilerin konumları tablo yardımıyla kolayca değiştirilerek yapılabilir.
Seed in-line row distance adjustment transmission. Seed spacing is made easily by changing the positions of the gears in the gear box with the help of the indicator table.



Ekilen araziye hassas olarak ölçebilen elektronik dekar sayacı.

Electronic hectare-Meter for measuring sown land.



TOPRAK ÖRTÜCÜ
SOIL COVERER

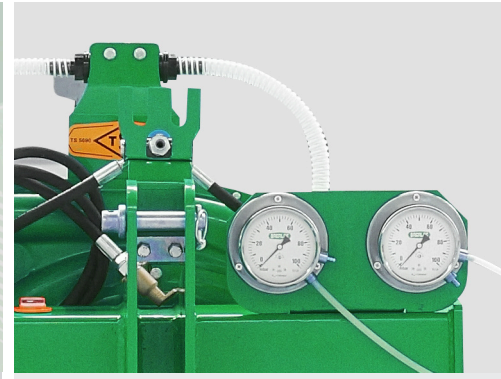

VAKUM ve BASINÇ GÖSTERGELERİ
VACUUM and PRESSURE INDICATORS



İlaçlama yapılacağında teker izi bırakmak için hava kesici

Air Stopper for leaving wheel tracks before chemical spraying

TEKNİK ÖZELLİKLER



TECHNICAL SPECIFICATIONS

Model Kodu	Ünite Sayısı	Toplam Boy (Şase)	Genişlik	Yükseklik	Sıra Arası Mesafe	Tohum Sandığı Hacmi	P.T.O. Devri	Traktör Gücü	Ağırlık (Gübre Sistemli)
Model Code	Number of Units	Total Length (Chassis)	Width	Height	Distance Between Rows	Seed Hopper Volume	P.T.O. Rpm	Tractor Power	Weight (With Fertilizer System)
	Adet Quantity	mm	mm	mm	cm	(Dm ³)	Rpm	(Min. Hp)	Kg
ŞK-PMB-11	11	3200	2500	1850	21	2.3 X 11	540	80	1375
ŞK-PMB-12	12	3500	2500	1850	21	2.3 X 12	540	85	1455
ŞK-PMB-13	13	3500	2500	1850	21	2.3 X 13	540	90	1525
ŞK-PMB-15	15	4000	2500	1850	21	2.3 X 15	540	95	1750



Üretimlerimizde, Değişen Teknoloji ve Çalışma Şartlarına göre Değişiklik Yapma Hakkımız Saklıdır.
We reserve the right to make changes in our productions according to Changing Technology and Working Conditions.



Sınırsız Yedek Parça ve Servis Hizmeti
Unlimited Spare Parts and Service